



*HSA21 helper a richiesta - *helper optional* - Helper auf Anfrage

code 8-11900262

Smontagomme semiautomatico con braccio a bandiera per cerchi fino a 21". Solido e affidabile

Semi-Automatic swing-arm tyre changer for rims up to 21". Strong and reliable

Halbautomatische Reifenmontiermaschine bis zur 21" Felgenreöße. Schnell und einfach



DATI TECNICI - TECHNICAL DATA - TECHNISCHE DATEN

Presca esterna	Outside Clamp	Spannbereich außen	10" - 21"
Presca interna	Inside Clamp	Spannbereich innen	12" - 23"
Diametro max. ruota	Max. wheel diameter	Maximaler Raddurchmesser	960 mm
Larghezza pneumatico	Tire Width	Reifenbreite	3" - 12"
Apertura stallonatore	Bead-breaker opening	Abdrückvorrichtung Öffnung	320 mm
Potenza stallonatura	Bead-breaking power	Abdrückkraft	2500 N
Pressione di esercizio aria	Working air Pressure	Arbeitsluftdruck	8 - 10 bar
Potenza motore (motore a due velocità con comando a pedale)	Motor Power (pedal control two speed motor)	Motorleistung (Pedalsteuerung Motor mit zwei Drehgeschwindigkeiten)	0,75 kW - 1.1 kW
Velocità rotazione mandrino	Chuck rotation speed	Spannfutter Rotationsgeschwindigkeit	7 rpm
Rumorosità durante il funzionamento	Noise level running	Laufender Geräuschpegel	<70 dB
Peso netto macchina	Nett Weight machine	Nettogewicht Maschine	179 kg
Peso lordo macchina	Gross Weight machine	Bruttogewicht Maschine	207 kg
Dimensione max imballo (LxPxH)	Max Dimension Imballage (LxBxH)	Max. Abmessungen Verpackung (LxBxH)	980x760x950 mm
per contenitore da 40"	for 40" container	Für 40" Behälter	56

DOTAZIONE - EQUIPMENT - AUSSTATTUNG

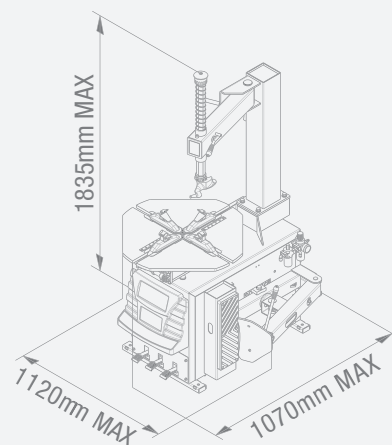

ACCESSORI CONSIGLIATI - RECOMMENDED ACCESSORIES - EMPFOHLENES ZUBEHÖR

- A C-01-1000012**
- Copertura leva da 20" (regolabile)
- Lever cover 20" (adjustable)
- Montageeisen Abdeckung 20" (einstellbar)
- B CT-S-0200002**
- Copertura di protezione bordo cerchio
- Rim edge protection cover
- Kunststoffschutz Felgenreand
- C CT-S-0200000**
- Pinza premitallone in plastica
- Plastic bead pressing clamp
- PVC wulsthalteklemme
- D CT-S-0110000**
- Attrezzo per cambio rapido testina di smontaggio
- Demount head quick change tool
- Schnellverschluss Demontagekopf
- E CT-S-0120002**
- Testina di smontaggio in plastica (per modelli con braccio a bandiera) - Plastic demount head (for swing arm model use) - Kunststoff Demontagekopf (für Schwingarmmodell Verwendung)
- F CT-S-0120000**
- Gruppo testina di smontaggio in plastica (per modelli con braccio a bandiera) Plastic demount head assy (for swing arm model use) - Kunststoff Demontagekopf Baugruppe (für Schwingarmmodell Verwendung)
- G C-21-8000100**
- Testina di smontaggio motocicletta
- Motorcycle demount head
- Motorrad-Montagekopf
- H C-21-8000001**
- Protettore testina di smontaggio piccola per motocicletta
- Motorcycle small demount head protector
- Kunststoffschutz klein für Motorrad-Montagekopf
- I CT-S-0500000**
Dispositivo di monitoraggio pressione pneumatici
Tire press assist device
Reifendruck Hilfsgerät
- J C-M-0400000**
- Adattatore motocicletta (stile rullo manuale), per uso con sistema a griffe STANDARD - Motorcycle adaptor (hand roller style), for STANDARD jaw system use - Motorrad Anpasser (Handrolle) für STANDARD Klauensystem Verwendung
- K C-M-0200000A**
- Adattatore motocicletta (stile rullo manuale), per uso con sistema a griffe STANDARD - Motorcycle adaptor (hand roller style), for STANDARD jaw system use - Motorrad Anpasser (Handrolle) für STANDARD Klauensystem Verwendung
- L CT-S-0600000**
- Basamento rotazione supporto ruota*
- Wheel support rotation base*
- Platte zum Rollen der Räder an der Abdrückschaufel*
*ancora non disponibile - not yet available - noch nicht verfügbar

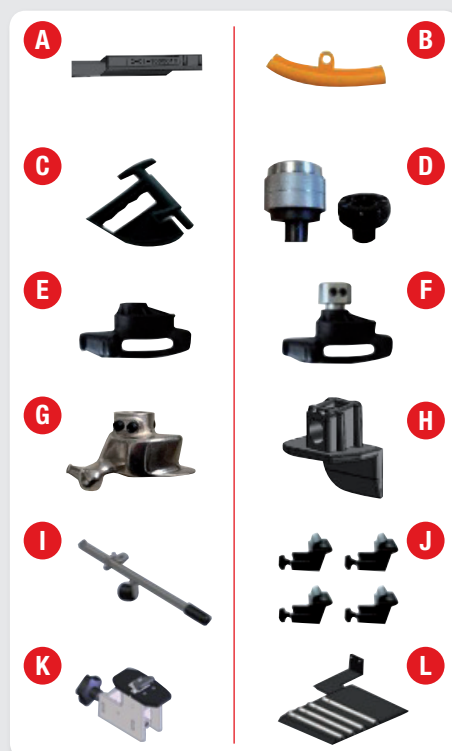

Per maggiori informazioni consultare il catalogo accessori completo - For further information, consult the complete accessories catalogue - Für weitere Informationen schlagen Sie bitte im Gesamtkatalog des Zubehörs nach



NEXION SPA - ITALY - Società unipersonale soggetta a direzione e coordinamento di Minio srl - A sole shareholder Minio company

www.corgi.com - info@corgi.com

